

TOOLS, FIXTURES

& ACCESSORIES

ENGLISH

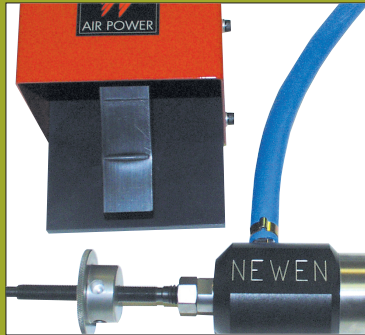
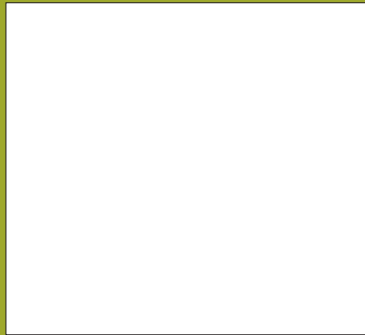
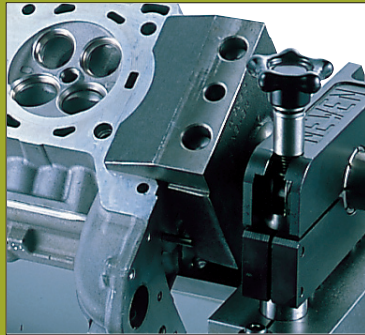
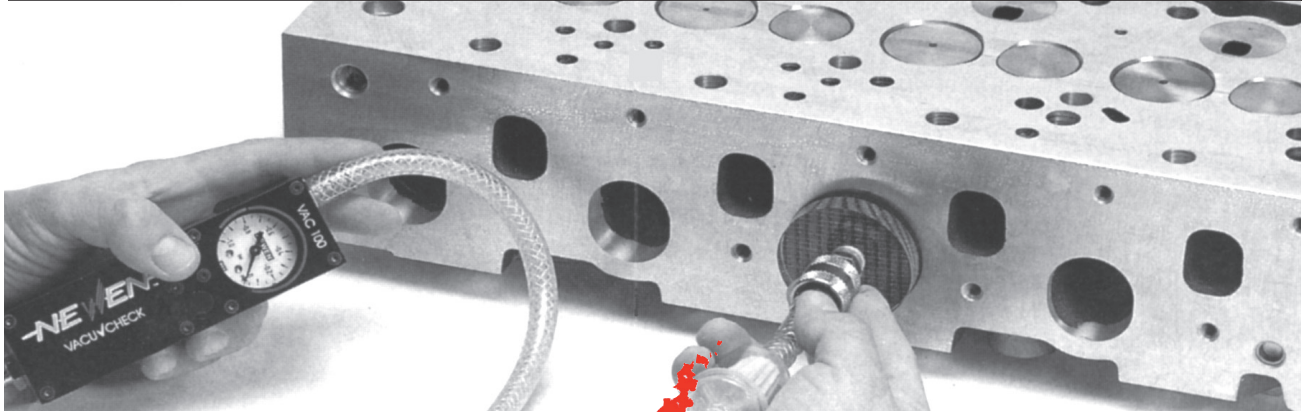



TABLE OF CONTENT

	Page(s)
Leak Down Vacuum Tester - Vacucheck™	4-5
• Spare Parts	5
Pneumatic Impact Puller - TUG-GUN™	6-10
• TUG100	6
• Collet Charts	7-8
• Spare Parts	9-10
Pre-Combustion Counterboring Tool - PCC100™	11-12
• PCC100	11
• Accessories	12
• Spare Parts	12
Carbide Form Tip Sharpener	13
Clamping Fixtures	14-19
• Palletizable, 360°, Rollover Clamping Fixtures & Accessories	14-16
• Multi-angle Swing Cylinder Head Clamping Fixture	17
• Multi-angle Cylinder Head Clamping Fixture	17
• Side Clamping Fixture	18
• Accessories & Spare Parts	19
SPRING MASTER™ Accessories & Spare Parts	20



VACU[✓]CHECK™

PATENTED

LEAKDOWN DETECTION

What sets the Vacucheck™ apart from any other vacuum tester on the market are its two built-in non-return valves that actually hold the vacuum that it creates.

Once the vacuum is created, the built-in valves shut automatically and the vacuum is held within a totally airtight volume.

The gauge of the Vacucheck™ is installed in line within a totally airtight volume.

The gauge of the Vacucheck™ is installed in line with the above mentioned circuit and allows the Vacucheck™ user to measure any leak accurately, regardless of its size, including micro-leaks that typically go unnoticed.

True leak detection can only occur after the pump is stopped.

Only Vacucheck™ lets you measure the leakdown time and detect leaks.

A two step process:

1. Create the vacuum
2. Monitor leak

Vacucheck™, another NEWEN® innovation....

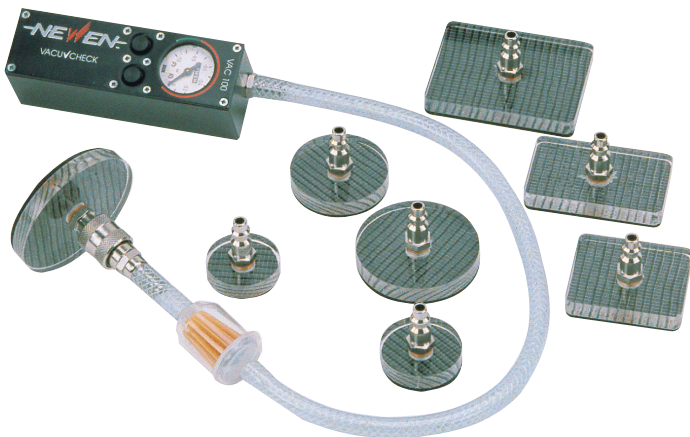

■ VAC100

The Vacucheck™ comes in a sturdy, yet light-weight carrying case, with 8 pads and two in-line filters. It is easy to carry, fits comfortably in your hand and only requires an airline to be operated.

TECHNICAL CHARACTERISTICS

Compressed Air:

Pressure: 70 to 90 PSI (5 to 6 bars)
 Air Flow: 1.12 cfm (0.53 l/second)

Depression:

Maximum Vacuum: 28.1" Hg (-94kPa)
 Time for evacuation of 1 liter of air
 14.94" Hg (-50kPa) = 2 seconds
 23.91" Hg (-80 kPa) = 5 seconds

Sound level: 60 dB(A)

Temperature: -4°F to +176°F (-20°C to + 80°C)





■ **VAC301**
Replacement plexiglass plate
Round
Diameter: 42mm (1.6535")



■ **VAC302**
Replacement plexiglass plate
Round
Diameter: 45mm (1.7716")



■ **VAC303**
Replacement plexiglass plate
Round
Diameter: 57mm (2.2441")



■ **VAC304**
Replacement plexiglass plate
Round
Diameter: 70mm (2.7559")

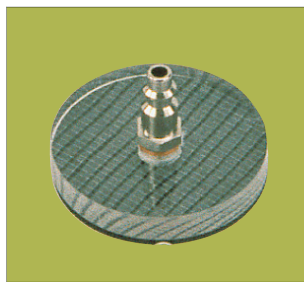

■ **VAC305**
Replacement plexiglass plate
Round
Diameter: 80mm (3.1496")



■ **VAC306**
Replacement plexiglass plate
Rectangular
Dimensions: 50mm x 80mm
(1.9685" x 3.1496")



■ **VAC307**
Replacement plexiglass plate
Rectangular
Dimensions: 55mm x 65mm
(2.1654" x 2.5591")



■ **VAC308**
Replacement plexiglass plate
Rectangular
Dimensions: 70mm x 90mm
(2.7559" x 3.5433")



■ **VAC323**
Replacement in-line filter
(unit: one filter).



■ **VAC329**
Replacement vacuum chip.



■ **VAC330**
Replacement gauge.



■ **VAC308**
Plexiglass Plate
Rectangular
Dimensions: 101.6mm X101.6mm
(4" x 4")

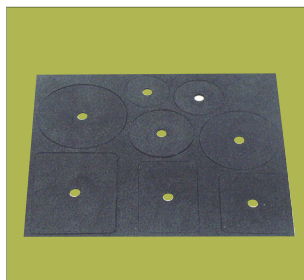

■ **VAC311**
Replacement pre-cut
self-adhesive foam pad
set (100% compatible with
Serdi pads).



■ **VAC326**
Aluminum plug for plexi-
glass plates.



■ **VAC322**
Quick Connection with rub-
ber tip for closed circuit.

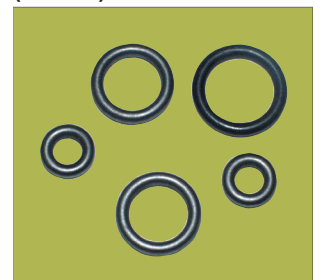

■ **VAC332**
Replacement O-ring set.

■ TUG100

TUG-GUN™, universal pneumatic impact puller.

Includes: (1) pneumatic impact puller, (1) foot pedal, (1) TUG600 - threaded shaft, (1) TUG602 - expansion nut, (1) TUG601 - set of 2 keepers, (1) TUG603 - wrench for expansion nut.



NEWEN® TUG-GUN™ (Patented) PNEUMATIC IMPACT PULLER

Nothing resist the TUG-GUN™:
oxidized studs, industrial engine
valve seats, freeze plugs...

- Powerfull (2000 strikes per minute)
- Universal
- Ensures even pressure around the seat
- No damage to the cylinder head and seat counterbores (no gouges, no chew ups...)
- Fast
- Easy to use
- Portable
- Countless applications: Studs, axles, rings, bearing casings, valve inserts, etc...

TUG-GUN™ by NEWEN®

“Machinists faced with the task of extracting valve seat inserts have only a few removal options - lever-type pullers, expansion-type pullers or heating with a torch so that the cylinder head expands quickly enough to allow the insert to pop out. Unfortunately, all three methods have the potential to damage the head and/or seat counterbores.

TUG-GUN™ uses a novel approach - pneumatic power - to quickly extract valve seat inserts within seconds, without damage. You begin by putting the proper collet and cone for the application onto the gun's threaded rod to hold everything in place. Once the correct spacers are selected, you place them between the collet's upper lip and the top of the valve seat. Next, position the TUG-GUN™ onto the seat, making sure that the lower collet lip engages the bottom of the seat. Finally, snug up the expansion nut, activate the gun and watch as the seat insert pulls effortlessly away from the counterbore.

NEWEN® makes collets to handle every head imaginable - from the smallest aluminum job to the gargantuan cast-iron diesels from Caterpillar, Detroit Diesel and Cummins. Optional attachments are also available to extract press-in studs....”

September 1994
Motor Magazine

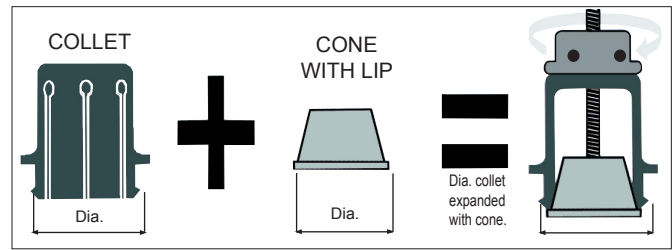
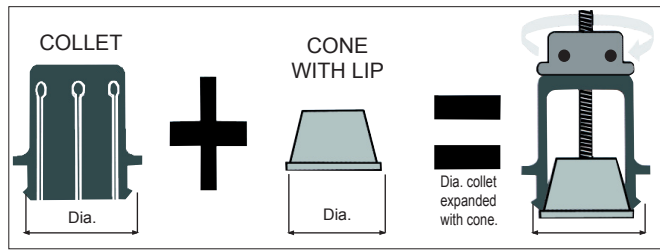

TUG301 Dia. 23mm (.906")	TUG419 Dia. 19mm (.748")	Dia. 24mm (.945")
TUG301 Dia. 23mm (.906")	TUG420 Dia. 20mm (.787")	Dia. 25mm (.984")
TUG302 Dia. 25mm (.984")	TUG421 Dia. 21mm (.827")	Dia. 26mm (1.024")
TUG302 Dia. 25mm (.984")	TUG422 Dia. 22mm (.866")	Dia. 27mm (1.063")
TUG303 Dia. 27mm (1.063")	TUG423 Dia. 23mm (.906")	Dia. 28mm (1.102")
TUG303 Dia. 27mm (1.063")	TUG424 Dia. 24mm (.945")	Dia. 29mm (1.142")
TUG304 Dia. 29mm (1.142")	TUG425 Dia. 25mm (.984")	Dia. 30mm (1.181")
TUG304 Dia. 29mm (1.142")	TUG426 Dia. 26mm (1.024")	Dia. 31mm (1.220")
TUG305 Dia. 31mm (1.220")	TUG427 Dia. 27mm (1.063")	Dia. 32mm (1.260")
TUG305 Dia. 31mm (1.220")	TUG428 Dia. 28mm (1.102")	Dia. 33mm (1.299")
TUG306 Dia. 33mm (1.299")	TUG429 Dia. 29mm (1.142")	Dia. 34mm (1.339")
TUG306 Dia. 33mm (1.299")	TUG430 Dia. 30mm (1.181")	Dia. 35mm (1.378")
TUG306 Dia. 33mm (1.299")	TUG431 Dia. 31mm (1.220")	Dia. 36mm (1.417")
TUG307 Dia. 35mm (1.378")		
TUG306 Dia. 33mm (1.299")	TUG432 Dia. 32mm (1.260")	Dia. 37mm (1.457")
TUG307 Dia. 35mm (1.378")		
TUG307 Dia. 35mm (1.378")	TUG433 Dia. 33mm (1.299")	Dia. 38mm (1.496")
TUG308 Dia. 37mm (1.457")		
TUG307 Dia. 35mm (1.378")	TUG434 Dia. 34mm (1.399")	Dia. 39mm (1.535")
TUG308 Dia. 37mm (1.457")		
TUG309 Dia. 39mm (1.535")	TUG435 Dia. 35mm (1.378")	Dia. 40mm (1.575")
TUG308 Dia. 37mm (1.457")	TUG436 Dia. 36mm (1.417")	Dia. 41mm (1.614")
TUG309 Dia. 39mm (1.535")		
TUG309 Dia. 39mm (1.535")	TUG437 Dia. 37mm (1.457")	Dia. 42mm (1.654")
TUG310 Dia. 41mm (1.614")		
TUG309 Dia. 39mm (1.535")	TUG438 Dia. 38mm (1.496")	Dia. 43mm (1.693")
TUG310 Dia. 41mm (1.614")		
TUG310 Dia. 41mm (1.614")	TUG439 Dia. 39mm (1.535")	Dia. 44mm (1.732")

TUG311 Dia. 43mm (1.693")	TUG439 Dia. 39mm (1.535")	Dia. 44mm (1.732")
TUG310 Dia. 41mm (1.614")	TUG440 Dia. 40mm (1.575")	Dia. 45mm (1.772")
TUG311 Dia. 43mm (1.693")		
TUG311 Dia. 43mm (1.693")	TUG441 Dia. 41mm (1.614")	Dia. 46mm (1.811")
TUG312 Dia. 45mm (1.772")		
TUG311 Dia. 43mm (1.693")	TUG442 Dia. 42mm (1.654")	Dia. 47mm (1.850")
TUG312 Dia. 45mm (1.772")		
TUG313 Dia. 47mm (1.850")	TUG443 Dia. 43mm (1.693")	Dia. 48mm (1.890")
TUG312 Dia. 45mm (1.772")	TUG444 Dia. 44mm (1.732")	Dia. 49mm (1.929")
TUG313 Dia. 47mm (1.850")		
TUG313 Dia. 47mm (1.850")	TUG445 Dia. 45mm (1.772")	Dia. 50mm (1.968")
TUG314 Dia. 49mm (1.929")		
TUG313 Dia. 47mm (1.850")	TUG446 Dia. 46mm (1.811")	Dia. 51mm (2.008")
TUG314 Dia. 49mm (1.929")		
TUG314 Dia. 49mm (1.929")	TUG447 Dia. 47mm (1.850")	Dia. 52mm (2.047")
TUG315 Dia. 51mm (2.008")		
TUG314 Dia. 49mm (1.929")	TUG448 Dia. 48mm (1.890")	Dia. 53mm (2.087")
TUG315 Dia. 51mm (2.008")		
TUG315 Dia. 51mm (2.008")	TUG449 Dia. 49mm (1.929")	Dia. 54mm (2.126")
TUG316 Dia. 53mm (2.087")		
TUG315 Dia. 51mm (2.008")	TUG450 Dia. 50mm (1.968")	Dia. 55mm (2.165")
TUG316 Dia. 53mm (2.087")		
TUG317 Dia. 55mm (2.165")	TUG451 Dia. 51mm (2.008")	Dia. 56mm (2.205")
TUG316 Dia. 53mm (2.087")	TUG452 Dia. 52mm (2.047")	Dia. 57mm (2.244")
TUG317 Dia. 55mm (2.165")		
TUG317 Dia. 55mm (2.165")	TUG453 Dia. 53mm (2.087")	Dia. 58mm (2.283")
TUG317 Dia. 55mm (2.165")	TUG454 Dia. 54mm (2.126")	Dia. 59mm (2.323")

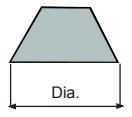
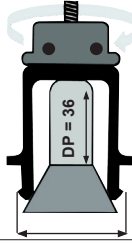
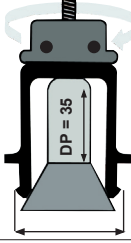
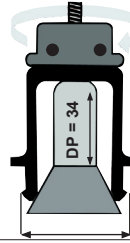
 <p>COLLET</p> <p>Dia.</p>	 <p>CONE WITHOUT LIP</p> <p>Dia.</p>	 <p>DP = 36</p> <p>Dia. collet expanded with cone and Distance Piece TUGDP36</p>	 <p>DP = 35</p> <p>Dia. collet expanded with cone and Distance Piece TUGDP35</p>	 <p>DP = 34</p> <p>Dia. collet expanded with cone and Distance Piece TUGDP34</p>
TUG302 Dia. 25mm (.984")	TUG519 Dia. 19mm (.748")	Dia. 26mm (1.024")	Dia. 26.5mm (1.043")	Dia. 27mm (1.063")
TUG302 Dia. 25mm (.984")	TUG520 Dia. 20mm (.787")	Dia. 27mm (1.063")	Dia. 27.5mm (1.083")	
TUG303 Dia. 27mm (1.063")	TUG521 Dia. 21mm (.827")	Dia. 28mm (1.102")	Dia. 28.5mm (1.122")	Dia. 29mm (1.142")
TUG303 Dia. 27mm (1.063")	TUG522 Dia. 22mm (.866")	Dia. 29mm (1.142")	Dia. 29.5mm (1.161")	Dia. 30mm (1.181")

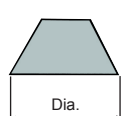
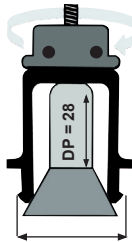
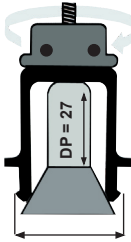
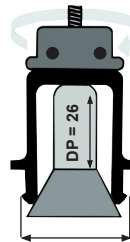
 <p>COLLET</p> <p>Dia.</p>	 <p>CONE WITHOUT LIP</p> <p>Dia.</p>	 <p>DP = 28</p> <p>Dia. collet expanded with cone and Distance Piece TUGDP28</p>	 <p>DP = 27</p> <p>Dia. collet expanded with cone and Distance Piece TUGDP27</p>	 <p>DP = 26</p> <p>Dia. collet expanded with cone and Distance Piece TUGDP26</p>
---	---	---	--	---

TUG304 Dia. 29mm (1.142")	TUG523 Dia. 23mm (.906")	Dia. 30mm (1.181")	Dia. 30.5mm (1.201")	Dia. 31mm (1.220")
TUG304 Dia. 29mm (1.142")	TUG524 Dia. 24mm (.945")	Dia. 31mm (1.220")	Dia. 31.5mm (1.240")	Dia. 32mm (1.260")
TUG305 Dia. 31mm (1.220")	TUG525 Dia. 25mm (.984")	Dia. 32mm (1.260")	Dia. 32.5mm (1.280")	Dia. 33mm (1.299")
TUG305 Dia. 31mm (1.220")	TUG526 Dia. 26mm (1.024")	Dia. 33mm (1.299")	Dia. 33.5mm (1.319")	Dia. 34mm (1.339")
TUG306 Dia. 33mm (1.299")	TUG527 Dia. 27mm (1.063")	Dia. 34mm (1.339")	Dia. 34.5mm (1.358")	Dia. 35mm (1.378")
TUG306 Dia. 33mm (1.299")	TUG528 Dia. 28mm (1.102")	Dia. 35mm (1.378")	Dia. 35.5mm (1.398")	Dia. 36mm (1.417")
TUG307 Dia. 35mm (1.378")	TUG529 Dia. 29mm (1.142")	Dia. 36mm (1.417")	Dia. 36.5mm (1.437")	Dia. 37mm (1.457")
TUG307 Dia. 35mm (1.378")	TUG530 Dia. 30mm (1.181")	Dia. 37mm (1.457")	Dia. 37.5mm (1.476")	Dia. 38mm (1.496")
TUG308 Dia. 37mm (1.457")	TUG531 Dia. 31mm (1.220")	Dia. 38mm (1.496")	Dia. 38.5mm (1.516")	Dia. 39mm (1.535")
TUG308 Dia. 37mm (1.457")	TUG532 Dia. 32mm (1.260")	Dia. 39mm (1.535")	Dia. 39.5mm (1.555")	Dia. 40mm (1.575")
TUG309 Dia. 39mm (1.535")	TUG533 Dia. 33mm (1.299")	Dia. 40mm (1.575")	Dia. 40.5mm (1.594")	Dia. 41mm (1.614")
TUG309 Dia. 39mm (1.535")	TUG534 Dia. 34mm (1.399")	Dia. 41mm (1.614")	Dia. 41.5mm (1.634")	Dia. 42mm (1.654")
TUG310 Dia. 41mm (1.614")	TUG535 Dia. 35mm (1.378")	Dia. 42mm (1.654")	Dia. 42.5mm (1.673")	Dia. 43mm (1.693")
TUG310 Dia. 41mm (1.614")	TUG536 Dia. 36mm (1.417")	Dia. 43mm (1.693")	Dia. 43.5mm (1.713")	Dia. 44mm (1.732")
TUG311 Dia. 43mm (1.693")	TUG537 Dia. 37mm (1.457")	Dia. 44mm (1.732")	Dia. 44.5mm (1.752")	Dia. 45mm (1.772")
TUG311 Dia. 43mm (1.693")	TUG538 Dia. 38mm (1.496")	Dia. 45mm (1.772")	Dia. 45.5mm (1.791")	Dia. 46mm (1.811")
TUG312 Dia. 45mm (1.772")	TUG539 Dia. 39mm (1.535")	Dia. 46mm (1.811")	Dia. 46.5mm (1.831")	Dia. 47mm (1.850")
TUG312 Dia. 45mm (1.772")	TUG540 Dia. 40mm (1.575")	Dia. 47mm (1.850")	Dia. 47.5mm (1.870")	Dia. 48mm (1.890")
TUG313 Dia. 47mm (1.850")	TUG541 Dia. 41mm (1.614")	Dia. 48mm (1.890")	Dia. 48.5mm (1.909")	Dia. 49mm (1.929")
TUG313 Dia. 47mm (1.850")	TUG542 Dia. 42mm (1.654")	Dia. 49mm (1.929")	Dia. 49.5mm (1.949")	Dia. 50mm (1.968")
TUG314 Dia. 49mm (1.929")	TUG543 Dia. 43mm (1.693")	Dia. 50mm (1.968")	Dia. 50.5mm (1.988")	Dia. 51mm (2.008")
TUG314 Dia. 49mm (1.929")	TUG544 Dia. 44mm (1.732")	Dia. 51mm (2.008")	Dia. 51.5mm (2.028")	Dia. 52mm (2.047")
TUG315 Dia. 51mm (2.008")	TUG545 Dia. 45mm (1.772")	Dia. 52mm (2.047")	Dia. 52.5mm (2.067")	Dia. 53mm (2.087")
TUG315 Dia. 51mm (2.008")	TUG546 Dia. 46mm (1.811")	Dia. 53mm (2.087")	Dia. 53.5mm (2.106")	Dia. 54mm (2.126")
TUG316 Dia. 53mm (2.087")	TUG547 Dia. 47mm (1.850")	Dia. 54mm (2.126")	Dia. 54.5mm (2.146")	Dia. 55mm (2.165")
TUG316 Dia. 53mm (2.087")	TUG548 Dia. 48mm (1.890")	Dia. 55mm (2.165")	Dia. 55.5mm (2.185")	Dia. 56mm (2.205")
TUG317 Dia. 55mm (2.165")	TUG549 Dia. 49mm (1.929")	Dia. 56mm (2.205")	Dia. 56.5mm (2.224")	Dia. 57mm (2.244")
TUG317 Dia. 55mm (2.165")	TUG550 Dia. 50mm (1.968")	Dia. 57mm (2.244")	Dia. 57.5mm (2.264")	Dia. 58mm (2.283")
TUG317 Dia. 55mm (2.165")	TUG551 Dia. 51mm (2.008")	Dia. 58mm (2.283")	Dia. 58.5mm (2.303")	Dia. 59mm (2.323")



**COLLET, SPACER
and CONE SETS
(FOR GENERAL AND
SELECTED
CATERPILLAR
APPLICATIONS).**

■ **COLLET, SPACER & CONE SETS FOR GENERAL APPLICATIONS:**

- **TUG301:** Collet Dia. 23-25mm (.905"-1.063"), 2 cones & 4 spacers.
- **TUG302:** Collet Dia. 25-27mm (.984"-1.063"), 2 cones & 4 spacers.
- **TUG303:** Collet Dia. 27-29mm (1.063"-1.142"), 2 cones & 4 spacers.
- **TUG304:** Collet Dia. 29-31mm (1.142"-1.220"), 2 cones & 4 spacers.
- **TUG305:** Collet Dia. 31-33mm (1.220"-1.299"), 2 cones & 4 spacers.
- **TUG306:** Collet Dia. 33.5-36.5mm (1.319"-1.437"), 4 cones & 4 spacers.
- **TUG307:** Collet Dia. 35.5-38.5mm (1.398"-1.516"), 4 cones & 4 spacers.
- **TUG308:** Collet Dia. 37.5-40.5mm (1.476"-1.594"), 4 cones & 4 spacers.
- **TUG309:** Collet Dia. 39.5-42.5mm (1.555"-1.673"), 4 cones & 4 spacers.
- **TUG310:** Collet Dia. 41.5-44.5mm (1.634"-1.752"), 4 cones & 4 spacers.
- **TUG311:** Collet Dia. 43.5-46.5mm (1.713"-1.831"), 4 cones & 4 spacers.
- **TUG312:** Collet Dia. 45.5-48.5mm (1.791"-1.909"), 4 cones & 4 spacers.
- **TUG313:** Collet Dia. 47.5-50.5mm (1.870"-1.988"), 4 cones & 4 spacers.
- **TUG314:** Collet Dia. 49.5-52.5mm (1.949"-2.067"), 4 cones & 4 spacers.
- **TUG315:** Collet Dia. 51.5-54.5mm (2.028"-2.146"), 4 cones & 4 spacers.
- **TUG316:** Collet Dia. 53.5-56.5mm (2.106"-2.224"), 4 cones & 4 spacers.
- **TUG317:** Collet Dia. 55.5-58.5mm (2.185"-2.303"), 4 cones & 4 spacers.

■ **COLLET & CONE SETS FOR SELECTED CATERPILLAR APPLICATIONS:**

- **TUG-CAT1:** 1 collet, 1 cone, seat ID 2.281", Ht. 0.625", CAT353 & like, IN.
- **TUG-CAT2:** 1 collet, 1 cone, seat ID 2.125", Ht. 0.625", CAT353 & like, EX.

**DISTANCE PIECE
(USED WITH LIPLISS CONES)**



- **TUG-DP20:** Distance piece, 20mm (.787")
- **TUG-DP21:** Distance piece, 21mm (.827")
- **TUG-DP22:** Distance piece, 22mm (.866")
- **TUG-DP23:** Distance piece, 23mm (.905")
- **TUG-DP24:** Distance piece, 24mm (.944")
- **TUG-DP25:** Distance piece, 25mm (.984")
- **TUG-DP26:** Distance piece, 26mm (1.023")
- **TUG-DP27:** Distance piece, 27mm (1.063")
- **TUG-DP28:** Distance piece, 28mm (1.102")
- **TUG-DP34:** Distance piece, 34mm (1.338")
- **TUG-DP35:** Distance piece, 35mm (1.377")
- **TUG-DP36:** Distance piece, 36mm (1.417")
- **TUG-DP29.3:** Distance piece, 29.3mm (1.153")-CAT
- **TUG-DP30.3:** Distance piece, 30.3mm (1.192")-CAT
- **TUG-DP31.3:** Distance piece, 31.3mm (1.232")-CAT

**LIPLISS CONE
(FOR VALVE SEATS WITH
CASTING INTERFERENCE AND
FREEZE PLUGS).**

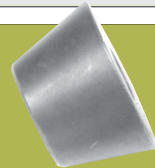

- **TUG519:** Lipless cone, dia. 19mm (.748")
- **TUG520:** Lipless cone, dia. 20mm (.787")
- **TUG521:** Lipless cone, dia. 21mm (.827")
- **TUG522:** Lipless cone, dia. 22mm (.866")
- **TUG523:** Lipless cone, dia. 23mm (.906")
- **TUG524:** Lipless cone, dia. 24mm (.945")
- **TUG525:** Lipless cone, dia. 25mm (.984")
- **TUG526:** Lipless cone, dia. 26mm (1.024")
- **TUG527:** Lipless cone, dia. 27mm (1.063")
- **TUG528:** Lipless cone, dia. 28mm (1.102")
- **TUG529:** Lipless cone, dia. 29mm (1.142")
- **TUG530:** Lipless cone, dia. 30mm (1.181")
- **TUG531:** Lipless cone, dia. 31mm (1.220")
- **TUG532:** Lipless cone, dia. 32mm (1.260")
- **TUG533:** Lipless cone, dia. 33mm (1.299")
- **TUG534:** Lipless cone, dia. 34mm (1.399")
- **TUG535:** Lipless cone, dia. 35mm (1.378")
- **TUG536:** Lipless cone, dia. 36mm (1.417")
- **TUG537:** Lipless cone, dia. 37mm (1.457")
- **TUG538:** Lipless cone, dia. 38mm (1.496")
- **TUG539:** Lipless cone, dia. 39mm (1.535")
- **TUG540:** Lipless cone, dia. 40mm (1.575")
- **TUG541:** Lipless cone, dia. 41mm (1.614")
- **TUG542:** Lipless cone, dia. 42mm (1.654")
- **TUG543:** Lipless cone, dia. 43mm (1.693")
- **TUG544:** Lipless cone, dia. 44mm (1.732")
- **TUG545:** Lipless cone, dia. 45mm (1.772")
- **TUG546:** Lipless cone, dia. 46mm (1.811")
- **TUG547:** Lipless cone, dia. 47mm (1.850")
- **TUG548:** Lipless cone, dia. 48mm (1.890")
- **TUG549:** Lipless cone, dia. 49mm (1.929")
- **TUG550:** Lipless cone, dia. 50mm (1.968")
- **TUG551:** Lipless cone, dia. 51mm (2.008")

**TUG-GUN™
ACCESSORIES
(STUDS EXTRACTION)**

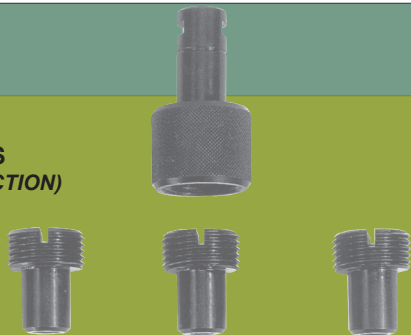

- **TUG-CK:** Stud puller connection set.
- **TUG-S-7/16x20:** Stud puller, 7/16" x 20
- **TUG-S-3/8x24:** Stud puller, 3/8" x 24
- **TUG-S-5/16x 24:** Stud puller, 5/16" x 24

**CONE WITH LIP
(FOR GENERAL
APPLICATIONS).**

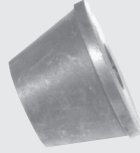

- TUG419: Cone with lip, dia. 19mm (.748")
- TUG420: Cone with lip, dia. 20mm (.787")
- TUG421: Cone with lip, dia. 21mm (.827")
- TUG422: Cone with lip, dia. 22mm (.866")
- TUG423: Cone with lip, dia. 23mm (.906")
- TUG424: Cone with lip, dia. 24mm (.945")
- TUG425: Cone with lip, dia. 25mm (.984")
- TUG426: Cone with lip, dia. 26mm (1.024")
- TUG427: Cone with lip, dia. 27mm (1.063")
- TUG428: Cone with lip, dia. 28mm (1.102")
- TUG429: Cone with lip, dia. 29mm (1.142")
- TUG430: Cone with lip, dia. 30mm (1.181")
- TUG431: Cone with lip, dia. 31mm (1.220")
- TUG432: Cone with lip, dia. 32mm (1.260")
- TUG433: Cone with lip, dia. 33mm (1.299")
- TUG434: Cone with lip, dia. 34mm (1.399")
- TUG435: Cone with lip, dia. 35mm (1.378")
- TUG436: Cone with lip, dia. 36mm (1.417")
- TUG437: Cone with lip, dia. 37mm (1.457")
- TUG438: Cone with lip, dia. 38mm (1.496")
- TUG439: Cone with lip, dia. 39mm (1.535")
- TUG440: Cone with lip, dia. 40mm (1.575")
- TUG441: Cone with lip, dia. 41mm (1.614")
- TUG442: Cone with lip, dia. 42mm (1.654")
- TUG443: Cone with lip, dia. 43mm (1.693")
- TUG444: Cone with lip, dia. 44mm (1.732")
- TUG445: Cone with lip, dia. 45mm (1.772")
- TUG446: Cone with lip, dia. 46mm (1.811")
- TUG447: Cone with lip, dia. 47mm (1.850")
- TUG448: Cone with lip, dia. 48mm (1.890")
- TUG449: Cone with lip, dia. 49mm (1.929")
- TUG450: Cone with lip, dia. 50mm (1.968")
- TUG451: Cone with lip, dia. 51mm (2.008")
- TUG452: Cone with lip, dia. 52mm (2.047")
- TUG453: Cone with lip, dia. 53mm (2.087")
- TUG454: Cone with lip, dia. 54mm (2.126")
- TUG455: Cone with lip, dia. 55mm (2.165")



■ **TUG600**
Replacement threaded shaft for TUG-GUN™.



■ **TUG603**
Replacement wrench for TUG602, expansion nut.

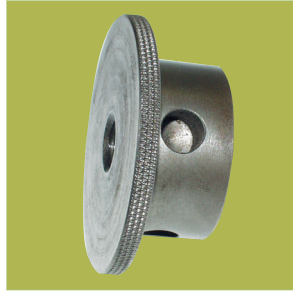

■ **TUG602**
Replacement expansion
nut for TUG-GUN™.



■ **TUG601**
Replacement keepers
(set of 2).



■ **TUG604**
Replacement Lock-nut.



■ **TUG605**
Replacement hose fitting.

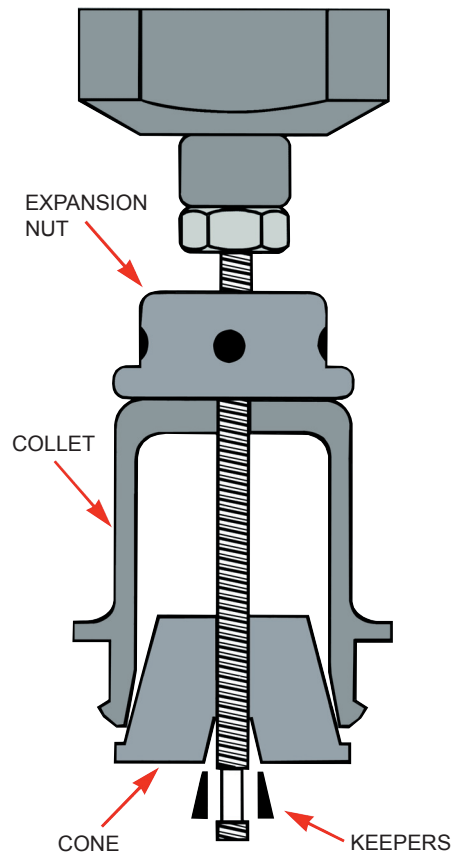

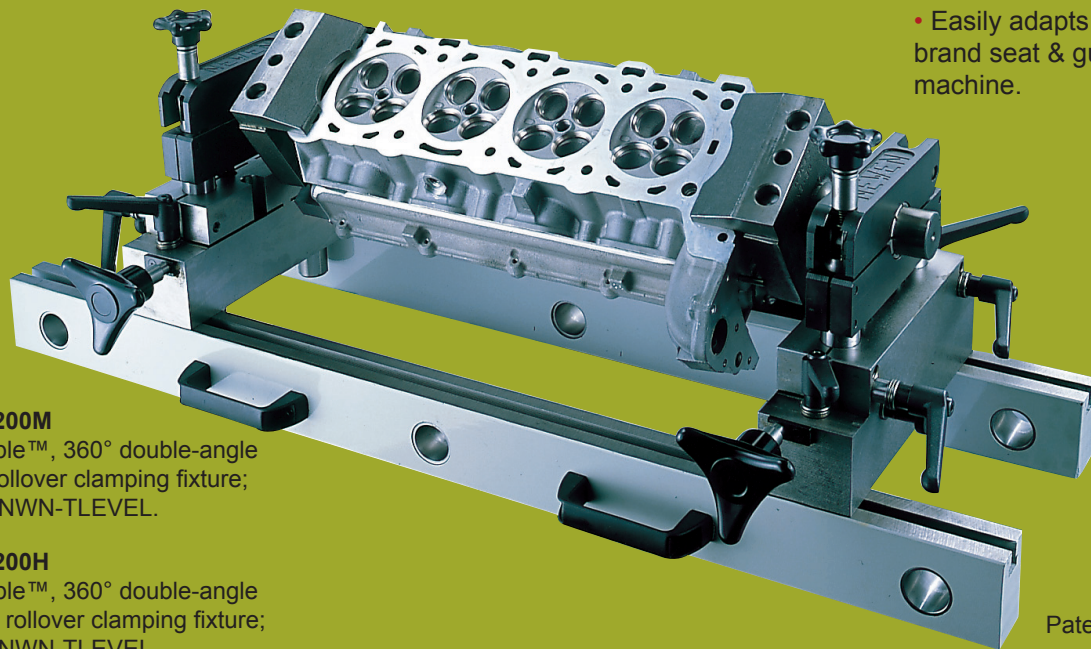

- Easily adapts to any brand seat & guide machine.

■ **SGC200M**
Palletizable™, 360° double-angle manual rolover clamping fixture; includes NWN-TLEVEL.

■ **SGC200H**
Palletizable™, 360° double-angle hydraulic rolover clamping fixture; includes NWN-TLEVEL.

Patented

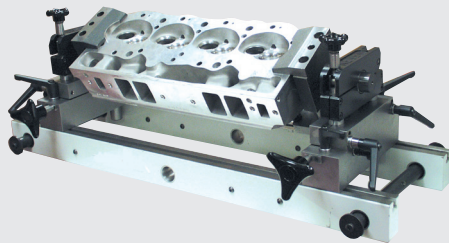

- NEWEN®'s most universal precision clamping system for automotive and light diesel cylinder heads. Allows quick positioning of most cylinder heads regardless of the valve guide angles. Also allows to simply raise cylinder heads to any desired level and to roll them over for various jobs.

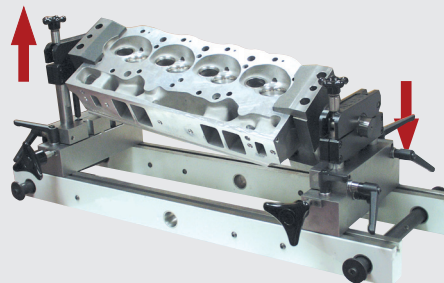
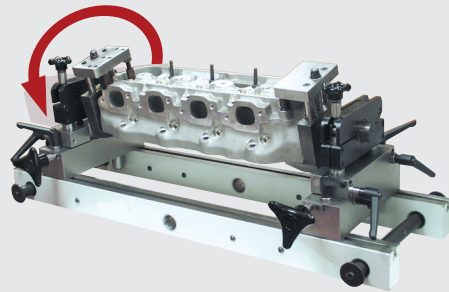

- This patented system is quick, universal, very rigid, user friendly and does not put any stress on cylinder heads owing to its independant jaws and spherical collet clamping system. **A must for any seat & guide machine.**

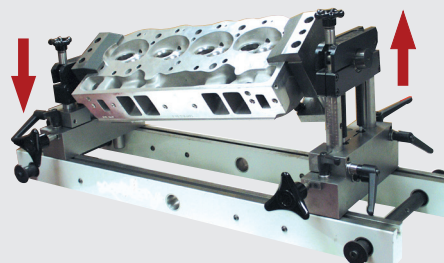
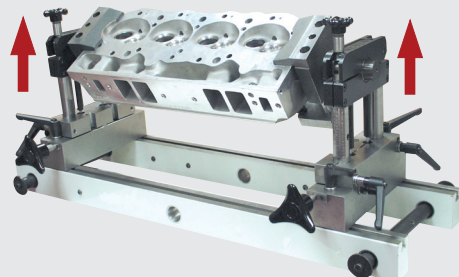

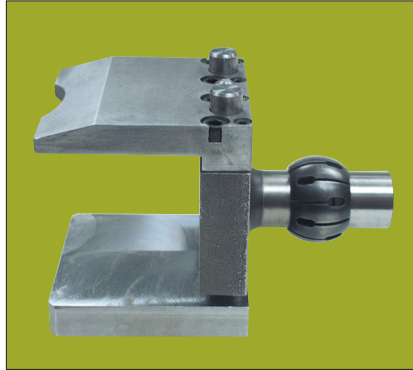

■ **SGC425**
Extended reach jaw for SGC200M & SGC200H clamping systems.

■ **SGC425-S**
Extended reach jaw for SGC200M-S clamping systems (for SUPER100™ machines).



■ **SGC416**
Set of two tall jaw columns & contact plates (8.58") for SGC200M & SGC200H clamping systems.

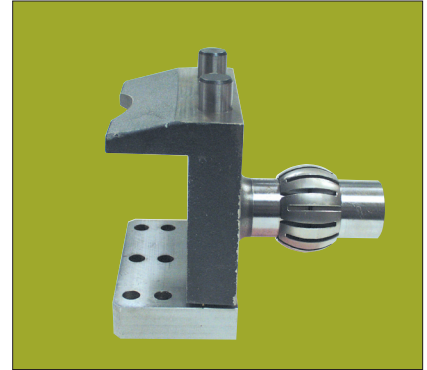

■ **SGC417**
Set of 2 additional clamping jaws for SGC200M & SGC200H clamping systems.

■ **SGC417-S**
Set of 2 additional clamping jaws for SGC200M-S clamping systems (for SUPER100™ machines).

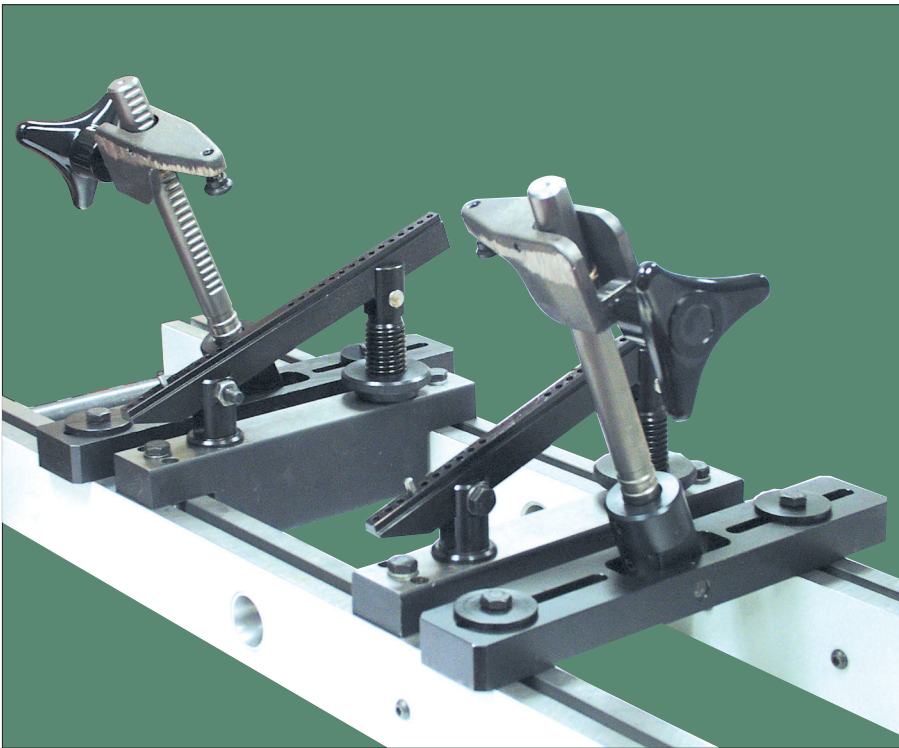

■ **SGC212**
Multi-angle cylinder head clamping fixture and set of 2 side clamps
(SGC704 & SGC705 included).

■ **SGC201**

Side clamping fixture with set of 2 riser blocks.

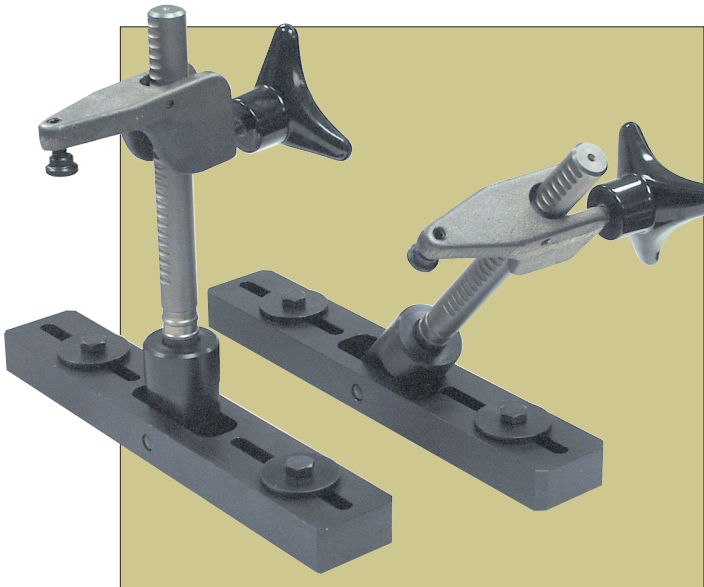
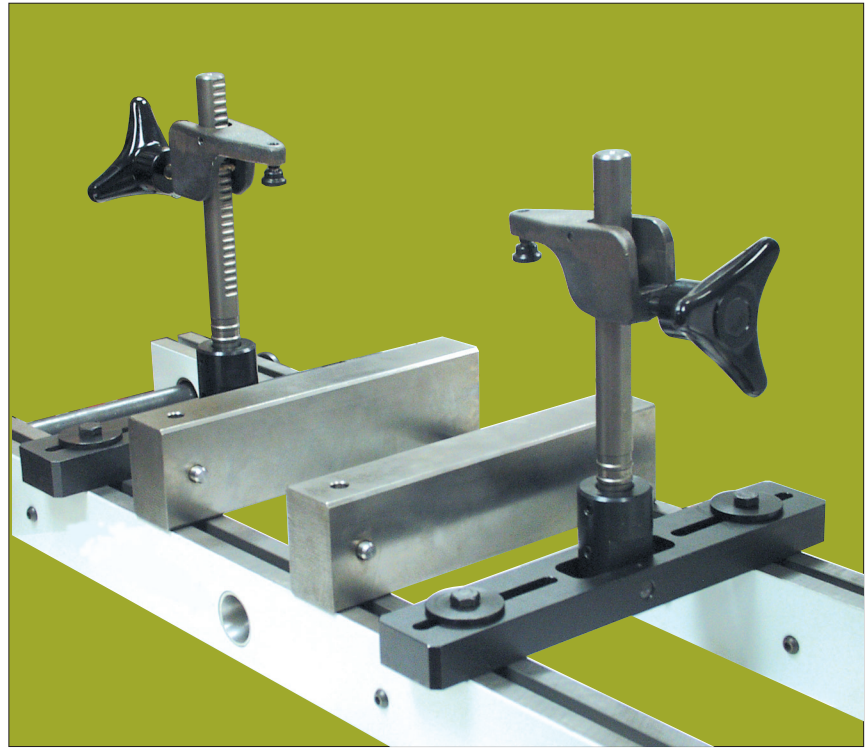

■ **SGC407**

Set of 2 side clamps.

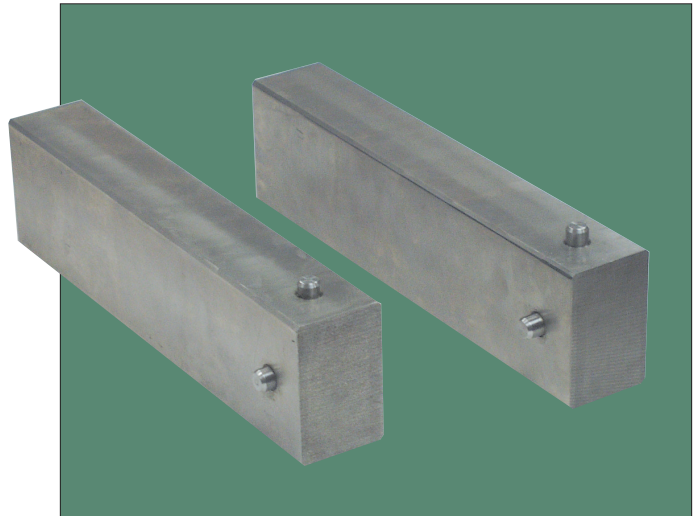

■ **SGC403**

Set of 2 precision machined cast iron cylinder head positioning blocks (riser blocks).

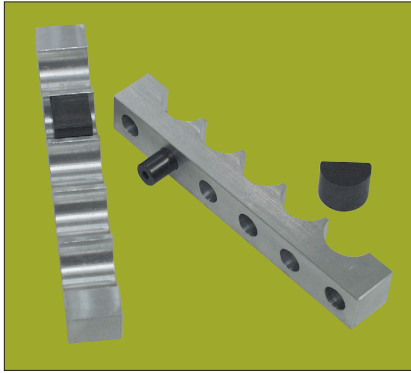

■ **SGC404**
Set of 2 aluminum pads for clamping aluminum cylinder heads (commonly used with SGC212).

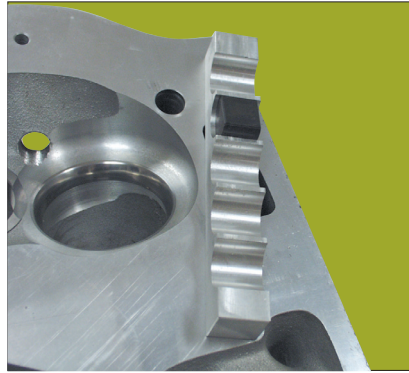

■ **SGC405**
Set of 2 long side clamp bars for SGC201, SGC212 or SGC213.



■ **SGC721**
Replacement parallels lock handle for SGC200M & SGC200H. Use SGC721-S for SGC200M-S.



■ **SGC765**
Replacement parallels lock handle for SGC213. Use SGC765-S for SGC213-S.



■ **SGC766**
Replacement side clamp.



■ **SGC710**
Replacement pivoting lock handle for SGC200M & SGC200M-S.



■ **SGC769**
Replacement side clamp lead screw for SGC699 (SGC200M, SGC200M-S & SGC200H) - comes as a set.

■ **SGC770**
Replacement side clamp lead screw for SGC416 (SGC200M & SGC200H) - comes as a set.

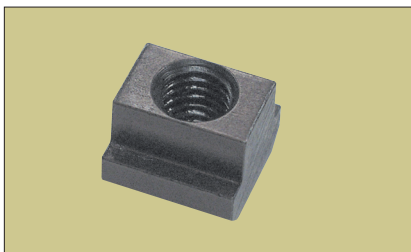

■ **SGC616**
Replacement T-nut.



NEWEN® • Tel: +1-760-233-0067 • Fax: +1-760-233-0068
Toll Free (USA): 1-800-639-3693

Email: contact@newen.com • Website: www.newen.com

Note: NEWEN® reserves the right to change or revise specifications and product design in connection with any feature of its products contained herein. Such changes do not entitle the buyer to corresponding changes, improvements, additions or replacement of equipment, supplies or accessories previously sold. Information contained herein is considered to be accurate based on information available at the time of printing. Should any discrepancy of information arise, NEWEN® recommends that user verify the discrepancy with NEWEN®.

& ACCESSORIES

TOOLS, FIXTURES

YOUR DISTRIBUTOR:

Ref: EQUIP-2012-EN

NEWEN®

www.newen.com